



The Ultimate in Fall Protection

**Instructions for the following series products:**

Tie-off Adapters and Scaffold Choker  
(See back page for specific model numbers.)

**USER INSTRUCTION MANUAL**  
**TIE-OFF ADAPTER AND SCAFFOLD CHOKER ANCHORAGE CONNECTORS**

This manual is intended to meet the Manufacturer's Instructions as required by ANSI-Z359.1 and should be used as part of an employee training program as required by OSHA.

**Figure 1 - Tie-off Adapter and Scaffold Choker Anchorage Connectors**

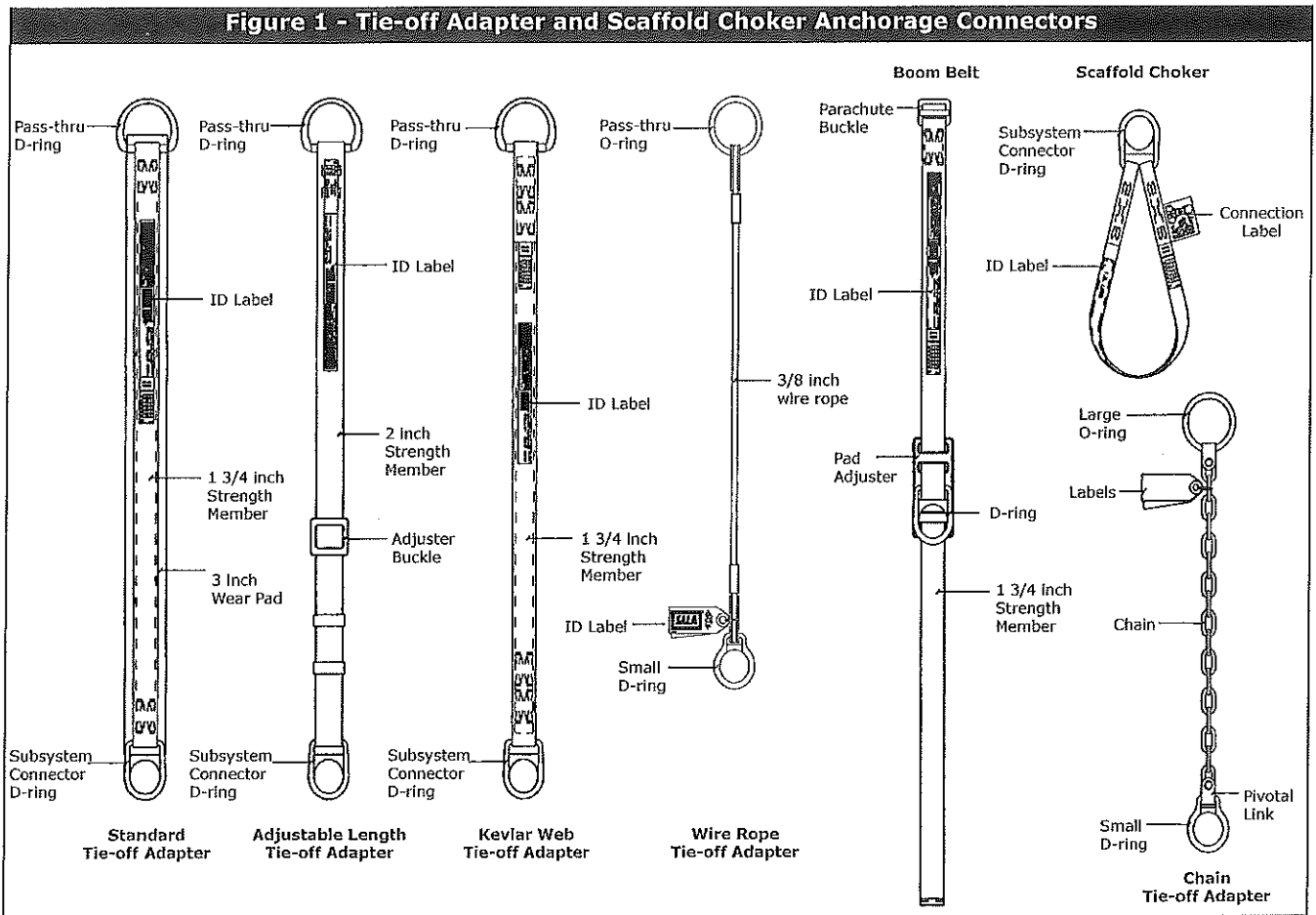

**WARNING:** This product is part of a personal fall arrest, restraint, work positioning, suspension, or rescue system. The user must follow the manufacturer's instructions for each component of the system. These instructions must be provided to the user of this equipment. The user must read and understand these instructions before using this equipment. Manufacturer's instructions must be followed for proper use and maintenance of this equipment. Alterations or misuse of this product, or failure to follow instructions, may result in serious injury or death.

**IMPORTANT:** If you have questions on the use, care, or suitability of this equipment for your application, contact DBI-SALA.

**IMPORTANT:** Record the product identification information from the ID label in the Inspection and Maintenance Log at the back of this of this manual.

## **DESCRIPTION**

**STANDARD TIE-OFF ADAPTER:** Pass through type tie-off adapter, 1-3/4 inch polyester webbing strength member, 3 inch wide polyester webbing wear pad. Available in various lengths. See Figure 1.

**ADJUSTABLE LENGTH TIE-OFF ADAPTER:** Pass through type tie-off adapter, 2 inch polyester webbing strength member with high strength edge for wear protection. Adjustable length. See Figure 1.

**KEVLAR WEB TIE-OFF ADAPTER:** Pass through type tie-off adapter, 1-3/4 inch Kevlar webbing strength member. Available in various lengths. See Figure 1.

**WIRE ROPE TIE-OFF ADAPTER:** Pass through type tie-off adapter, 3/8 inch diameter wire rope. Available in various lengths. See Figure 1.

**BOOM BELT:** Parachute buckle type belt, 1-3/4 inch polyester webbing strength member. See Figure 1.

**SCAFFOLD CHOKER:** Choker type anchorage connector, 1 inch polyester webbing strength member. Available in various lengths. See Figure 1.

**CHAIN TIE-OFF ADAPTER:** Pass through type tie-off adapter, zinc-plated stainless steel. See Figure 1.

## **1.0 APPLICATIONS**

**1.1 PURPOSE:** The tie-off adapter, boom belt, and scaffold choker is designed to be used as an anchorage connector for a personal fall arrest, restraint, work positioning, suspension, or rescue system. Tie-off adapters and scaffold chokers may be used as an anchorage connector for a horizontal lifeline if the system is designed, installed and used under the supervision of a qualified person. Do not hang, lift, or support tools or equipment from this equipment.

- Kevlar web tie-off adapters should be used when working with high temperature tools or materials, or in high temperature environments (foundries, chemical manufacturing, steel fabrication, emergency rescue services, fire services, welders, oil industry, nuclear industry).

**A. PERSONAL FALL ARREST:** The anchorage connector is used as a component of a personal fall arrest system. Personal fall arrest systems typically include a full body harness and a connecting subsystem, (energy absorbing lanyard). Maximum permissible free fall is 6 feet.

**B. RESTRAINT:** The anchorage connector is used as a component of a restraint system to prevent the user from reaching a fall hazard. Restraint systems typically include a full body harness and a lanyard or restraint line. No vertical free fall permitted.

**C. WORK POSITIONING:** The anchorage connector is used as a component of a work positioning system to support the user at a work position. Work positioning systems typically include a full body harness, positioning lanyard, and a back-up personal fall arrest system. Maximum permissible free fall is 2 feet.

**D. PERSONNEL RIDING:** The anchorage connector is used as a component of a personnel riding system to suspend or transport the user vertically. Personnel riding systems typically include a full body harness, boatswain's chair or seat board, and a back-up personal fall arrest system. No vertical free fall permitted.

**E. RESCUE:** The anchorage connector is used as a component of a rescue system. Rescue systems are configured depending on the type of rescue. No vertical free fall permitted.

**1.2 LIMITATIONS:** Consider the following application limitations before using this product:

**A. CAPACITY:** These anchorage connectors are designed for use by persons with a combined weight (clothing, tools, etc.) of no more than 310 lbs. No more than one personal protective system may be connected at one time.

**B. FREE FALL:** Personal fall arrest systems used with this equipment must be rigged to limit the free fall to 6 feet (ANSI Z359.1). See personal fall arrest system manufacturer's instructions for more information. Restraint systems must be rigged so that no vertical free fall is possible. Work positioning systems must be rigged so that free fall is limited to 2 feet or less. Personnel riding systems must be rigged so that no vertical free fall is possible. Rescue systems must be rigged so that no vertical free fall is possible.

**Figure 2 - Fall Clearance**

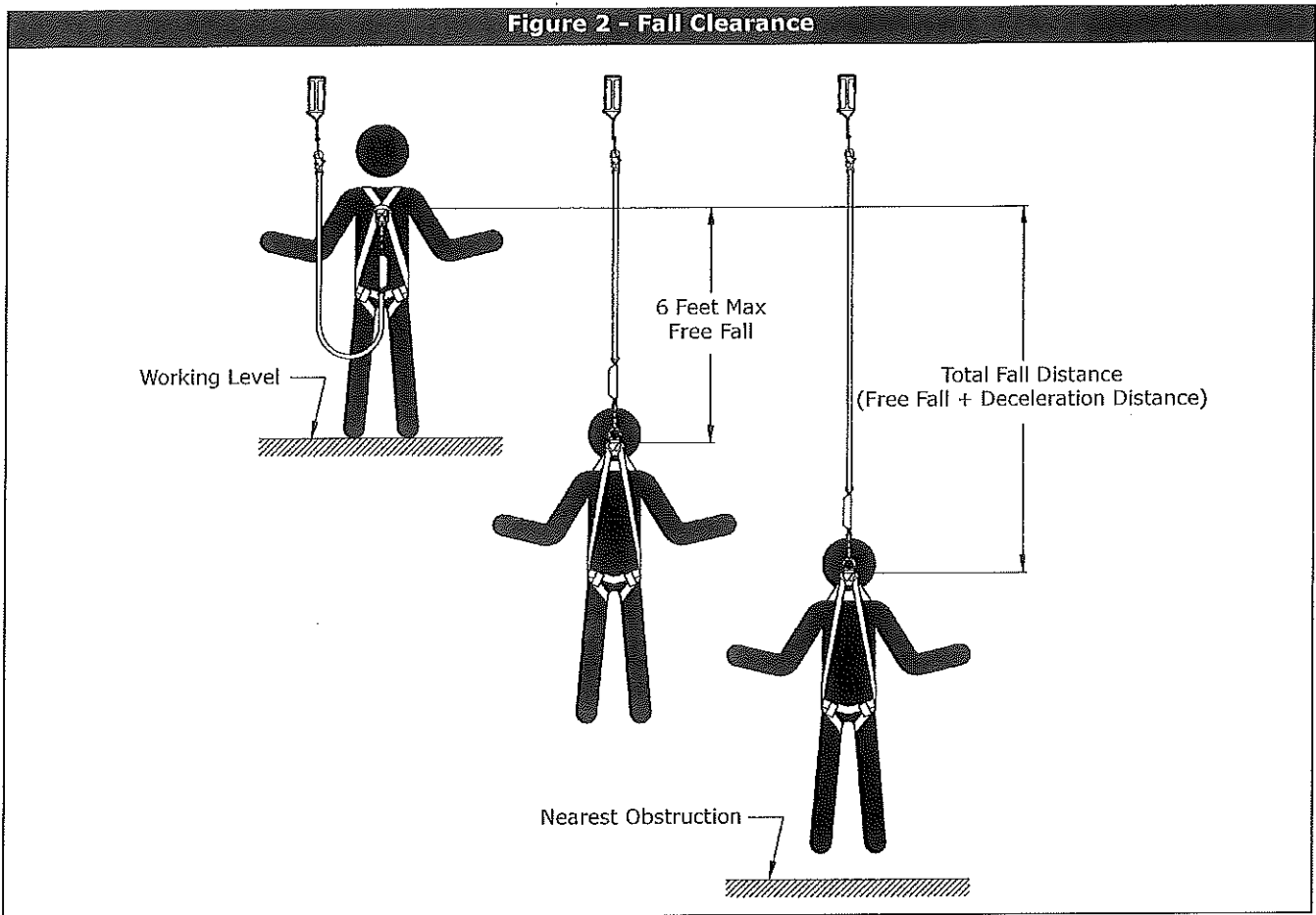

**C. FALL CLEARANCE:** See Figure 2. There must be sufficient clearance below the user to arrest a fall before the user strikes the ground or other obstruction. The clearance required is dependent on the following factors:

- Elevation of anchorage connector
- Deceleration distance
- Worker height
- Connecting subsystem length
- Movement of harness attachment element
- Free fall distance

See personal fall arrest system manufacturer's instructions for more information.

**D. SWING FALLS:** See Figure 3. Swing falls occur when the anchorage point is not directly above the point where a fall occurs. The force of striking an object in a swing fall may cause serious injury or death. Minimize swing falls by working as close to the anchorage point as possible. Do not permit a swing fall if injury could occur. Swing falls will significantly increase the clearance required when a self retracting lifeline or other variable length connecting subsystem is used.

**E. ENVIRONMENTAL HAZARDS:** Use of this equipment in areas with environmental hazards may require additional precautions to prevent injury to the user or damage to the equipment. Hazards may include, but are not limited to; heat, chemicals, corrosive environments, high voltage power lines, gases, moving machinery, and sharp edges. Contact DBI-SALA if you have questions about using this equipment where environmental hazards exist.

**F. TRAINING:** This equipment must be installed and used by persons trained in its correct application and use. See section 4.0.

**Figure 3 - Swing Falls**

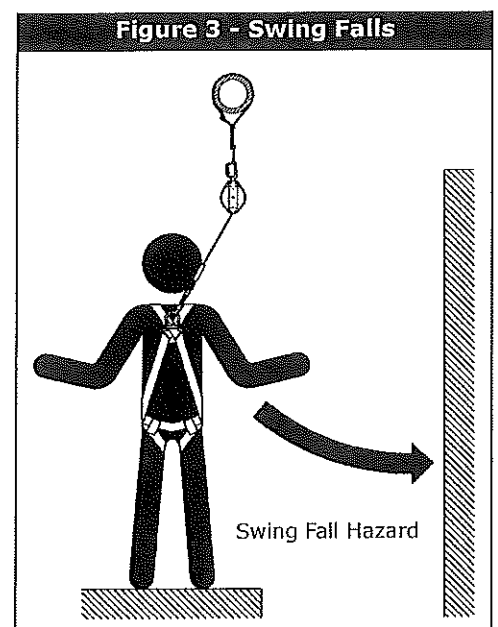

**1.3 APPLICABLE STANDARDS:** Refer to national standards, including ANSI Z359.1; and local, state, and federal requirements for more information on personal fall arrest systems and associated components.

## 2.0 SYSTEM REQUIREMENTS

**2.1 COMPATIBILITY OF COMPONENTS:** DBI-SALA equipment is designed for use with DBI-SALA approved components and subsystems only. Substitutions or replacements made with non-approved components or subsystems may jeopardize compatibility of equipment and may effect the safety and reliability of the complete system.

**2.2 COMPATIBILITY OF CONNECTORS:** Connectors are considered to be compatible with connecting elements when they have been designed to work together in such a way that their sizes and shapes do not cause their gate mechanisms to inadvertently open regardless of how they become oriented. Contact DBI-SALA if you have any questions about compatibility.

Connectors ( hooks, carabiners, and D-rings) must be capable of supporting at least 5,000 lbs. (22.2kN). Connectors must be compatible with the anchorage or other system components. Do not use equipment that is not compatible. Non-compatible connectors may unintentionally disengage. See Figure 4. Connectors must be compatible in size, shape, and strength. Self locking snap hooks and carabiners are required by ANSI Z359.1 and OSHA.

**Figure 4 - Unintentional Disengagement (Roll-out)**

If the connecting element that a snap hook (shown) or carabiner attaches to is undersized or irregular in shape, a situation could occur where the connecting element applies a force to the gate of the snap hook or carabiner. This force may cause the gate (of either a self-locking or a non-locking snap hook) to open, allowing the snap hook or carabiner to disengage from the connecting point.

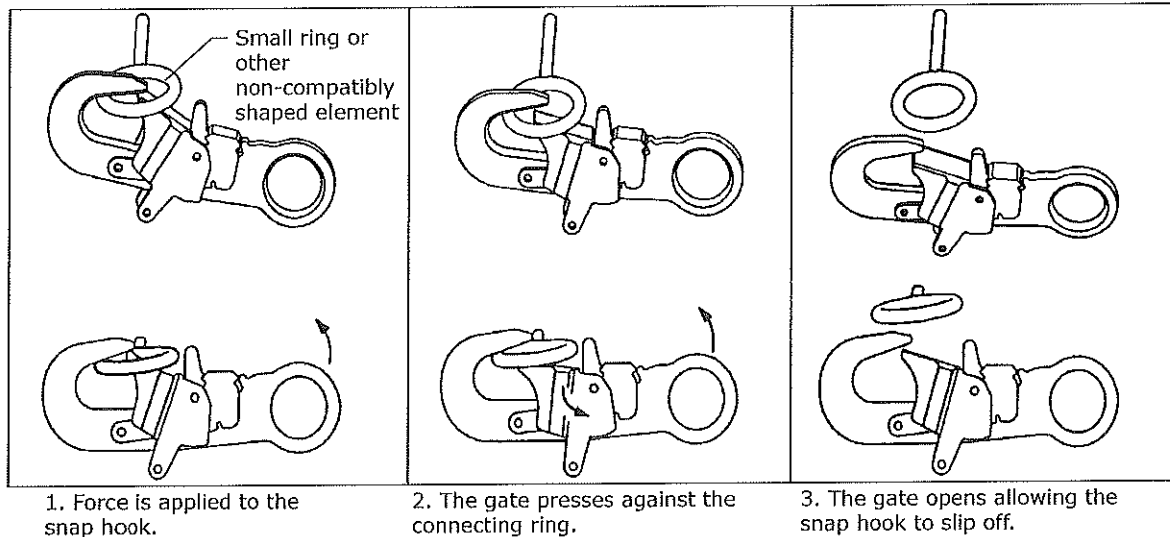

**2.3 MAKING CONNECTIONS:** Only use self-locking snap hooks and carabiners with this equipment. Only use connectors that are suitable to each application. Ensure all connections are compatible in size, shape and strength. Do not use equipment that is not compatible. Ensure all connectors are fully closed and locked.

DBI-SALA connectors (snap hooks and carabiners) are designed to be used only as specified in each product's user's instructions. See Figure 5 for inappropriate connections. DBI-SALA snap hooks and carabiners should not be connected:

- A. To a D-ring to which another connector is attached.
- B. In a manner that would result in a load on the gate.

**NOTE:** Large throat opening snap hooks should not be connected to standard size D-rings or similar objects which will result in a load on the gate if the hook or D-ring twists or rotates. Large throat snap hooks are designed for use on fixed structural elements such as rebar or cross members that are not shaped in a way that can capture the gate of the hook.

C. In a false engagement, where features that protrude from the snap hook or carabiner catch on the anchor and without visual confirmation seems to be fully engaged to the anchor point.

D. To each other.

E. Directly to webbing or rope lanyard or tie-back (unless the manufacturer's instructions for both the lanyard and connector specifically allows such a connection).

F. To any object which is shaped or dimensioned such that the snap hook or carabiner will not close and lock, or that roll-out could occur.

G. In a manner that does not allow the connector to align properly while under load.

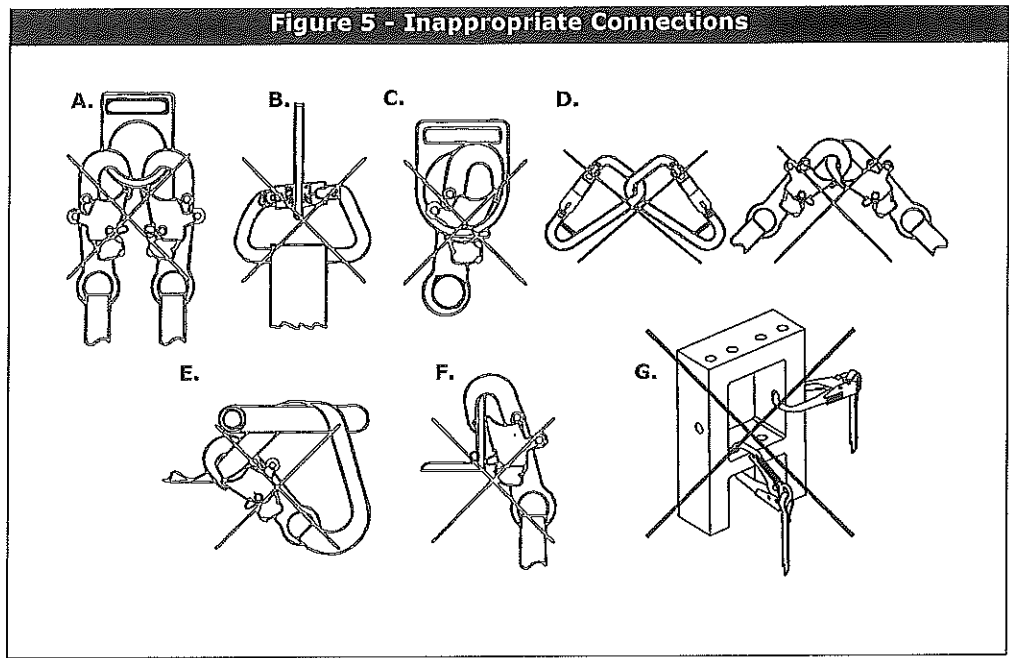

**2.4 PERSONAL FALL ARREST SYSTEM:** Personal fall arrest systems used with this equipment must meet applicable state, federal, OSHA, and ANSI requirements. A full body harness must be worn when this equipment is used as a component of a personal fall arrest system. As required by OSHA, the personal fall arrest system must be capable of arresting the user's fall with a maximum arresting force of 1,800 lbs., and limit the free fall to 6 feet or less. If the maximum free fall distance must be exceeded, the employer must document, based on test data, that the maximum arresting force will not be exceeded, and the personal fall arrest system will function properly.

When a free fall greater than 6 feet, and up to a maximum of 12 feet is possible, DBI-SALA recommends using a personal fall arrest system incorporating a DBI-SALA Force2 Energy Absorbing Lanyard. DBI-SALA has performed testing using the Force2 Energy Absorbing Lanyard in free falls up to 12 feet to ensure the maximum arresting force does not exceed 1,800 lbs., and the system functions properly. The results of these tests are listed in the user instruction manual provided with Force2 Energy Absorbing Lanyards.

**2.5 ANCHORAGE STRUCTURE:** This equipment is intended to be installed on structures capable of meeting the anchorage strength requirements specified below. The anchorage connector must be of sufficient length to wrap completely around the anchorage.

**2.6 ANCHORAGE STRENGTH:** The anchorage strength required is dependent on the application. Following are anchorage strength requirements for specific applications:

**A. FALL ARREST:** The structure to which the anchorage connector is attached must sustain static loads applied in the directions permitted by the fall arrest system of at least: 3,600 lbs. with certification of a qualified person, or 5,000 lbs. without certification. See ANSI Z359.1 for certification definition. When more than one personal fall arrest system is attached to an anchorage, the strengths stated above must be multiplied by the number of personal fall arrest systems attached to the anchorage.

From OSHA 1926.500 and 1910.66: Anchorages used for attachment of a personal fall arrest system shall be independent of any anchorage being used to support or suspend platforms, and must support at least 5,000 lbs. per user attached; or be designed, installed, and used as part of a complete personal fall arrest system which maintains a safety factor of at least two, and is supervised by a qualified person.

- B. RESTRAINT:** The structure to which the anchorage connector is attached must sustain static loads applied in the directions permitted by the restraint system of at least 3,000 lbs. When more than one restraint system is attached to an anchorage, the strengths stated above must be multiplied by the number of restraint systems attached to the anchorage.
- C. WORK POSITIONING:** The structure to which the anchorage connector is attached must sustain static loads applied in the directions permitted by the work positioning system of at least 3,000 lbs., or twice the potential impact load, whichever is greater. When more than one work positioning system is attached to an anchorage, the strengths stated above must be multiplied by the number of work positioning systems attached to the anchorage.
- D. PERSONNEL RIDING:** The structure to which the anchorage connector is attached must sustain static loads applied in the directions permitted by the personnel riding system of at least 2,500 lbs. When more than one personnel riding system is attached to an anchorage, the strengths stated above must be multiplied by the number of personnel riding systems attached to the anchorage.
- E. RESCUE:** The structure to which the anchorage connector is attached must sustain static loads applied in the directions permitted by the rescue system of at least 2,500 lbs. When more than one rescue system is attached to an anchorage, the strengths stated above must be multiplied by the number of rescue systems attached to the anchorage.

### 3.0 INSTALLATION AND USE

**WARNING:** Do not alter or intentionally misuse this equipment; your safety may depend on it. Consult with DBI-SALA if using this equipment with components or subsystems other than those described in this manual. Some subsystem and component combinations may interfere with the operation of this equipment.

**WARNING:** Consult with your doctor if you doubt your fitness to safely absorb the shock from a fall arrest. Age and fitness can seriously affect your ability to withstand falls. Pregnant women and minors must not use this equipment.

- 3.1 BEFORE EACH USE** of this equipment inspect it according to section 5.0 of this manual.
- 3.2 PLAN** your system before installation. Consider all factors that will affect your safety during use of this equipment. The following list gives important points to consider when planning your system:
  - A. ANCHORAGE:** Select an anchorage that meets the requirements specified in section 2.0.
  - B. SHARP EDGES:** Avoid working where system components may be in contact with, or abrade against, unprotected sharp edges. Inspection frequency should be increased when an anchorage connector is installed around sharp edges.
  - C. AFTER A FALL:** Components which have been subjected to the forces of arresting a fall must be removed from service and destroyed.
  - D. RESCUE:** The employer must have a rescue plan when using this equipment. The employer must have the ability to perform a rescue quickly and safely.
- 3.3 ANCHORAGE CONNECTOR INSTALLATION:**
  - A. ANCHORAGE CONNECTOR LOCATION:** Select a location on a suitable strength anchorage that will provide the best safety to the user.
  - B. STRUCTURE:** The structure to which the anchorage connector is attached must be free of corrosion, cracks, deformities, or other defects that may weaken the structure. Do not attach an anchorage connector to a vertical structure unless a means of restraining the connector from sliding down the structure is present. If the anchorage connector were to slide down the structure in a fall arrest situation, serious injury to the user is possible. The scaffold choker is designed to attach to round, smooth structures, such as structural scaffold tubing.

- C. INSTALLING THE TIE-OFF ADAPTER:** Place the tie-off adapter over the anchorage with the labels facing out. The D-rings must be hanging below the anchorage as shown in Figure 6. With the tie-off adapter positioned on the anchorage, pass the small D-ring through the large D-ring as shown in Figure 7. Slide the large D-ring up to the anchorage, over the webbing attached to the small D-ring. Pull the small D-ring down to take up slack that was made by moving the large D-ring up. The tie-off adapter should be tightly wrapped around the anchorage with the small D-ring hanging free as shown in Figure 8. Multiple passes of the tie-off adapter around the anchorage may be made to shorten the length. Pass the small D-ring through the large D-ring on each pass.

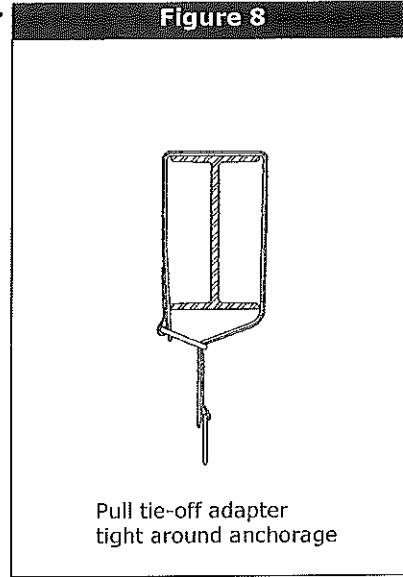
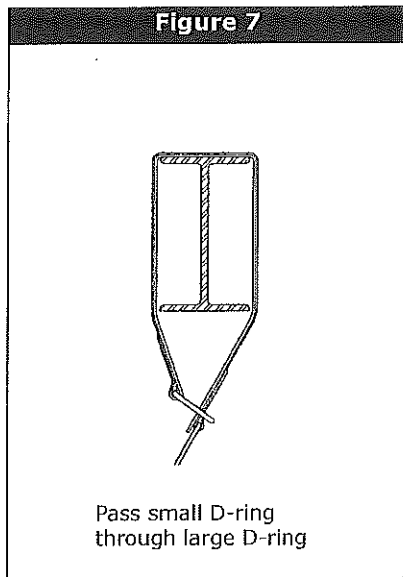
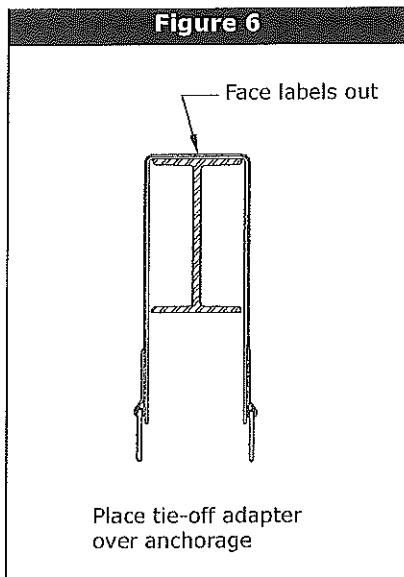

- INSTALLING THE CABLE TIE-OFF ADAPTER:** Place the tie-off adapter over the anchorage. The D-rings must be hanging below the anchorage as shown in Figure 9. With the tie-off adapter positioned on the anchorage, pass the small D-ring through the large O-ring as shown in Figure 10. Slide the large O-ring up to the anchorage, over the cable attached to the small D-ring. Pull the small D-ring down to take up slack that was made by moving the large O-ring up. The tie-off adapter should be tightly wrapped around the anchorage with the small D-ring hanging free as shown in Figure 11. Multiple passes of the tie-off adapter around the anchorage may be made to shorten the length. Pass the small D-ring through the large O-ring on each pass.

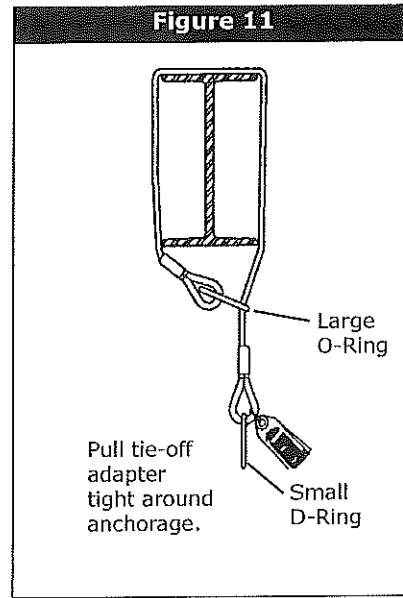
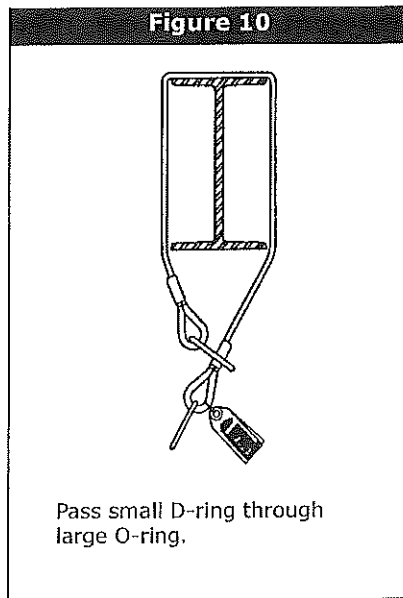
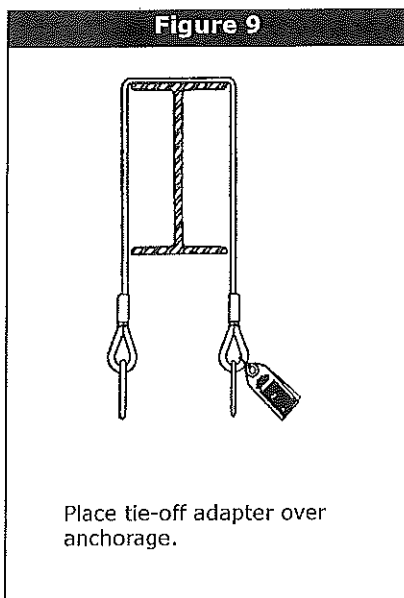

- E. INSTALLING THE CHAIN TIE-OFF ADAPTER:** Place the tie-off adapter over the anchorage. The D-rings must be hanging below the anchorage as shown in Figure 12. With the tie-off adapter positioned on the anchorage, pass the small D-ring through the large O-ring as shown in Figure 13. Slide the large O-ring up to the anchorage, over the chain attached to the small D-ring. Pull the small D-ring down to take up slack that was made by moving the large O-ring up. The tie-off adapter should be tightly wrapped around the anchorage with the small D-ring hanging free as shown in Figure 14. Multiple passes of the tie-off adapter around the anchorage may be made to shorten the length. Pass the small D-ring through the large O-ring on each pass.

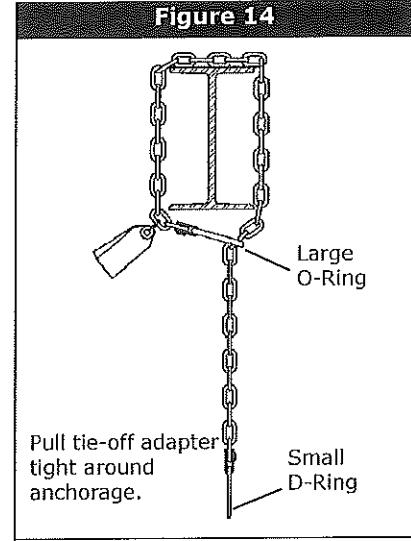
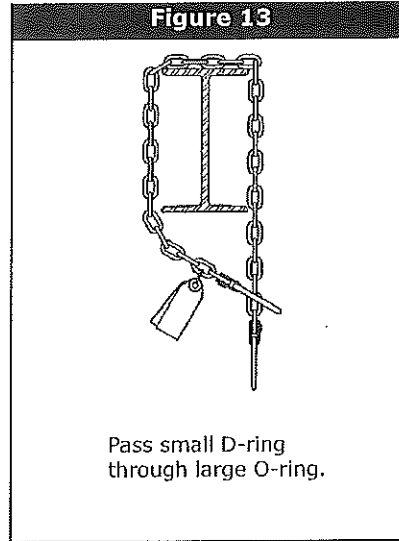
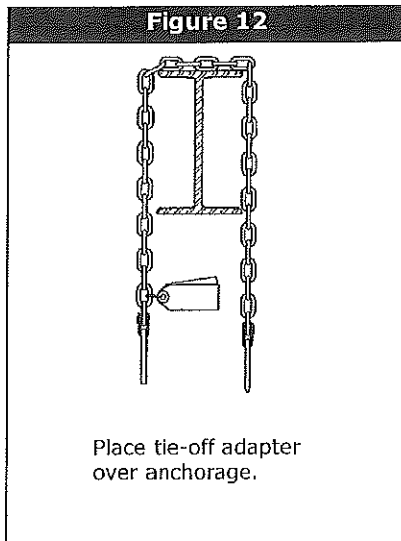

- F. INSTALLING THE SCAFFOLD CHOKER:** Place the scaffold choker over the anchorage with the labels facing out. The D-ring must be hanging below the anchorage as shown in Figure 15. Pass the D-ring under the anchorage and through the web loop as shown in Figure 16. Pull the D-ring down to take up slack as shown in Figure 17. The scaffold choker should be tightly wrapped around the anchorage.

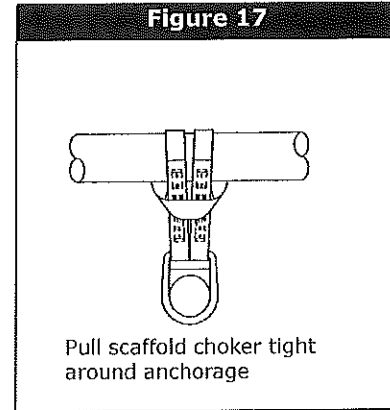
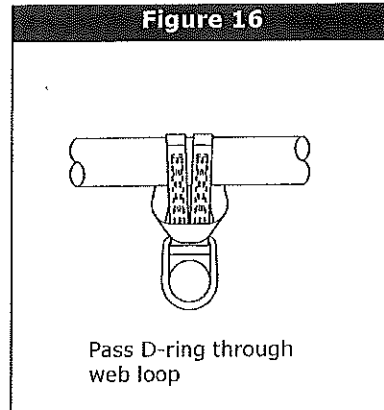
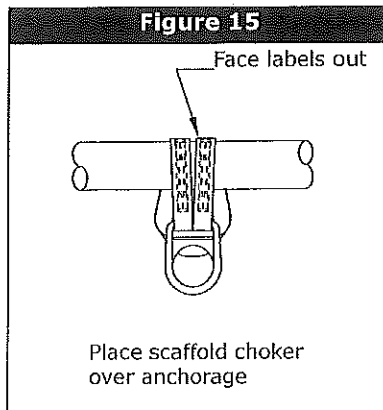



**G. INSTALLING THE BOOM BELT:** Wrap the belt around the boom so that the D-ring is on top as shown in Figure 18. Weave end of web through the parachute buckle (see Figure 19), leave at least 3 inches of web extended past the buckle as shown in Figure 18.

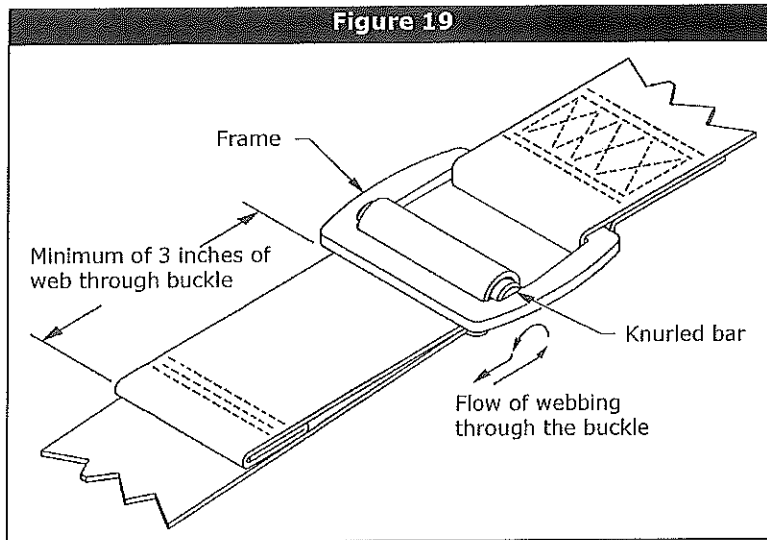
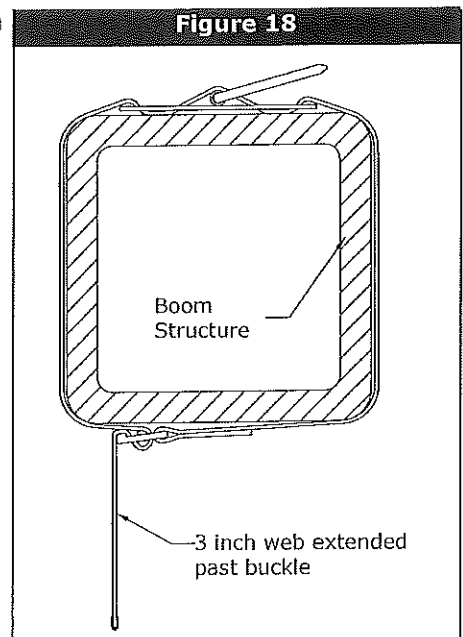

**IMPORTANT:** The Boom Belt is to be used on structures with smooth rounded edges only.

**WARNING:** The anchorage connector must be tight against the anchoring structure as shown in Figures 8, 11, 14, and 17. Do not leave slack in the tie-off adapter, this may increase the free fall distance in the event of a fall. See Figure 20.

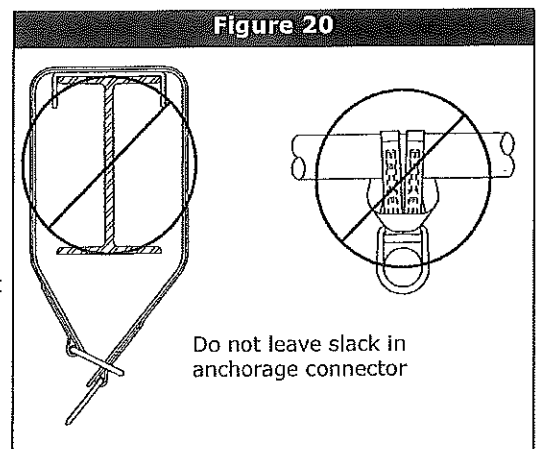

**3.4 MAKING CONNECTIONS:** When using a hook to connect to the anchorage connector, ensure roll-out cannot occur. Roll-out occurs when interference between the hook and mating connector causes the hook gate to unintentionally open and release. Self locking snap hooks and carabiners should be used to reduce the possibility of roll-out. Do not use hooks or connectors that will not completely close over the attachment object.

**3.5 CONNECTING TO THE ANCHORAGE CONNECTOR:** Connect to the installed anchorage connector with a self locking snap hook or self locking carabiner only. For tie-off adapters, connect your subsystem to the small D-ring only (do not attach to both D-rings, see Figure 21). Do not use a knot to connect a lifeline to the anchorage connector. Do not pass lanyard or lifeline through the anchorage connector D-ring and hook back into lanyard or lifeline. Ensure connections are fully closed and locked. See Figure 22 for connection of typical fall arrest or restraint equipment to the anchorage connector. When using an energy absorbing lanyard, connect the energy absorber "pack" end to the harness. Ensure self retracting lifeline is positioned so that retraction is not hindered. Always protect lifeline or lanyard from abrading against sharp or abrasive surfaces in your work area. Ensure all connections are compatible in size, shape, and strength. Never connect more than one personal protective system to a single anchorage connector.

**WARNING:** The tie-off adapter small D-ring must pass through the large D-ring. The connecting subsystem must be connected to the small D-ring only. Do not attach the subsystem to both D-rings. See Figure 21.

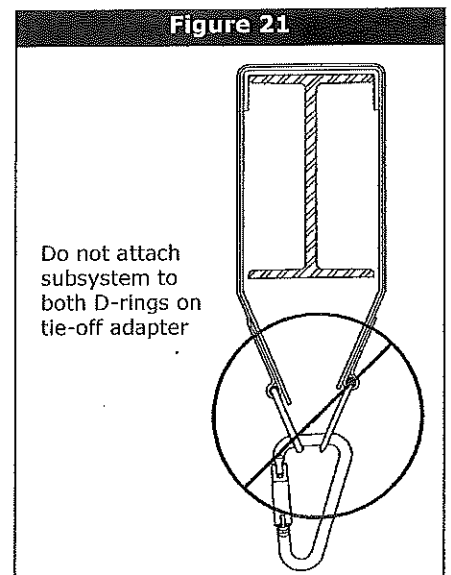

**Figure 22 - Connecting to the Anchorage Connector**

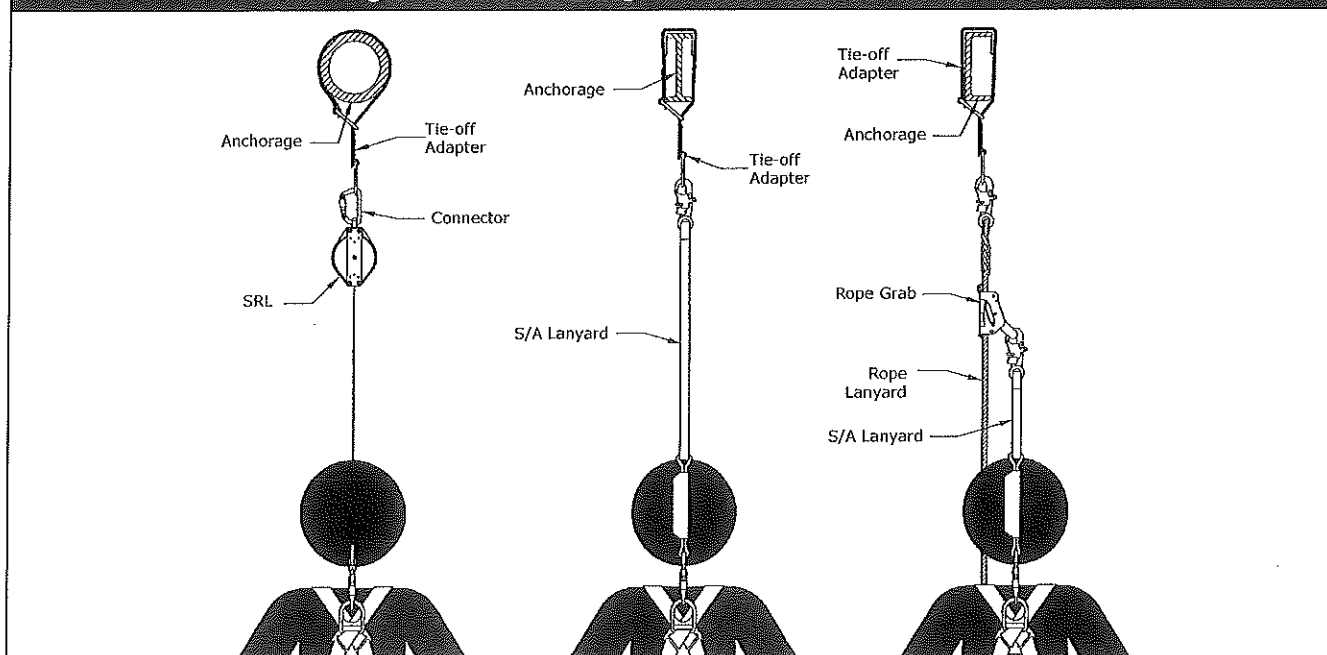

## 4.0 TRAINING

- 4.1 It is the responsibility of the user to assure they are familiar with these instructions, and are trained in the correct care and use of this equipment. User must also be aware of the operating characteristics, application limits, and the consequences of improper use of this equipment.

**IMPORTANT:** Training must be conducted without exposing the trainee to a fall hazard. Training should be repeated on a periodic basis.

## 5.0 INSPECTION

### 5.1 FREQUENCY:

- **Before each use** inspect the tie-off adaptor according to sections 5.2 and 5.3.
- **Formal Inspection:** A formal inspection of the anchorage connector must be performed at least annually by a competent other than the user. The frequency of formal inspections should be based on conditions of use or exposure. See sections 5.2 and 5.3. Record the inspection results in the Inspection and Maintenance Log at the back of this manual.

**IMPORTANT:** If this equipment has been subjected to fall arrest forces it must be immediately removed from service and destroyed.

### 5.2 INSPECTION STEPS:

- Step 1.** Inspect the anchorage connector hardware, including, chain, pivotal link, D-rings, O-ring, cable, thimble, ferrules, rivets, and adjuster buckle. These items must not be damaged, broken, distorted or have any sharp edges, burrs, cracks, worn parts, or corrosion.
- Step 2. Webbing:** Inspect the anchorage connector webbing and stitching. The webbing must be free of frayed, cut or broken fibers. Check for tears, abrasions, mold, or discoloration. The webbing must be free of knots, excessive soiling, heavy paint build-up, and rust staining. Check for chemical or heat damage, indicated by brown, discolored, or brittle areas. Check for ultraviolet degradation, indicated by discoloration and the presence of splinters or slivers on the webbing surface. Check for pulled or cut stitches. Broken stitches may be an indication that the anchorage connector has been impact loaded and must be removed from service. All the above factors are known to reduce the strength of the anchorage connector. Damaged or questionable anchorage connectors must be removed from service.

**Wire Rope:** Inspect the wire rope for cuts, kinks, broken wires, bird-caging, corrosion, welding splatter, chemical contact areas, rust, corrosion, broken wires, severely abraded areas or other obvious faults. Inspect thimbles for cracks or damage.

**Step 3.** Ensure the condition of the anchorage will support the anchorage connector loads. See section 2.6. An anchorage connector connected to a damaged anchorage must not be used.

**Step 4.** Ensure the anchorage connector is securely attached to the anchoring structure. If anchorage connector is loose, do not use. Reconnect the anchorage connector to the anchorage according to section 3.3.

**Step 5.** Inspect each system component or subsystem according to associated manufacturer's instructions.

**Step 6.** Record the inspection date and results in the Inspection and Maintenance Log.

**5.3** If inspection reveals an unsafe or defective condition, remove anchorage connector from service and destroy.

**IMPORTANT:** Only DBI-SALA or parties authorized in writing may make repairs to this equipment.

## **6.0 MAINTENANCE, STORAGE**

**6.1** Clean anchorage connector with water and a mild detergent solution. Wipe off hardware with a clean, dry cloth and hang to air dry. Do not force dry with heat. An excessive build-up of dirt, paint, etc. may prevent the anchorage connector from working properly, and may degrade the webbing to a point where it has become weakened and should be removed from service. If you have questions concerning the condition of your anchorage connector, or have any doubt about putting it into service, contact DBI-SALA.

**6.2** Store the anchorage connector in a cool, dry, clean environment, out of direct sunlight. Avoid areas where chemical vapors exist. Thoroughly inspect the anchorage connector after extended storage.

## **7.0 SPECIFICATIONS**

### **Standard Tie-Off Adapter:**

**Hardware:** Forged alloy steel D-rings.

**Webbing:** 1-3/4 inch polyester strength member, 3 inch polyester wear pad.

**MINIMUM BREAKING STRENGTH:** 5,000 lbs. when loaded within the recommended working range.

**CAPACITY:** 310 lbs. (one person)

Meets ANSI Z359.1 and OSHA requirements.

### **Adjustable Tie-Off Adapter:**

**HARDWARE:** Forged alloy steel D-rings, alloy steel adjuster buckle.

**WEBBING:** 2 inch polyester strength member with high strength edge.

**MINIMUM BREAKING STRENGTH:** 5,000 lbs. when loaded within the recommended working range.

**CAPACITY:** 310 lbs. (one person)

Meets ANSI Z359.1 and OSHA requirements.

### **Kevlar Web Tie-off Adapter:**

**Hardware:** Forged alloy steel D-rings.

**Webbing:** 1-3/4 inch Kevlar strength member.

**Minimum Breaking Strength:** 5,000 lbs. when loaded within the recommended working range.

**Capacity:** 310 lbs. (one person)

Meets OSHA requirements.

### **Wire Rope Tie-off Adapter:**

**Hardware:** Zinc Plated Steel, Stainless Steel.

**Cable:** wire rope, 3/8 inch diameter, 7x9 strand, 302 or 304 stainless steel, breaking strength of 12,000 lbs min.

**Minimum Breaking Strength:** 5,000 lbs. when loaded within the recommended working range.

**Capacity:** 310 lbs. (one person)

Meets ANSI Z359.1 and OSHA requirements.

**Boom Belt:**

**Hardware:** Forged alloy steel D-ring.

**Webbing:** 1-3/4 inch polyester strength member.

**Minimum Breaking Strength:** 5,000 lbs. when loaded within the recommended working range.

**Capacity:** 310 lbs. (one person)

Meets ANSI Z359.1 and OSHA requirements.

**Chain Tie-off Adapter:**

**HARDWARE:** Zinc-plated Steel, Stainless Steel

**MINIMUM BREAKING STRENGTH:** 5,000 lbs. when loaded within the recommended working range.

**CAPACITY:** 310 lbs. (one person)

Meets ANSI Z359.1 and OSHA requirements

**Scaffold Choker:**

**Hardware:** Forged alloy steel D-rings.

**Webbing:** 1 inch polyester strength member

**Minimum Breaking Strength:** 5,000 lbs. when loaded within the recommended working range.

**Capacity:** 310 lbs. (one person)

Meets ANSI Z359.1 and OSHA requirements.



***This instruction applies to the following models:***

1001250	1002120	1170003	3321986	3400889	3400975	5003070	5900571
1001251	1002130	1170003	3321987	3400890	3400976	5003080	5900572
1002001	1002140	1170003	3321987	3400900	3400977	5003080	5900573
1002002	1002141	1201390	3321988	3400900B	3400978	5003085	5900574
1002004	1002200	1201391	3321988	3400900C	3400979	5003085	5900700
1002005	1002201	1201392	3321989	3400901	3400979B	5003100	5900701
1002007	1002202	1201393	3321989	3400901C	3400980	5003100	5900702
1002008	1002203	1201394	3321994	3400902	3400981	5003100C	5900703
1002009	1002204	1201395	3321994	3400902B	3400982	5003100C	5900704
1002010	1002205	1201396	3321995	3400902C	3400983	5003120	5900705
1002011	1002206	1201397	3321995	3400903	3400984	5003120	5900706
1002012	1002207	1201398	3321996	3400910	3400987	5003125	7600008
1002013	1002300	1201399	3321996	3400911	3400988	5003125	7600008
1002014	1002325	1201420	3321997	3400912	3400990	5003130	7600009
1002015	1003000	1201421	3321997	3400912B	3400990B	5003130	7600009
1002016	1003000ALT	1201422	3321998	3400913	3400991	5003150	7600010
1002017	1003006	1201423	3321998	3400914	3400991B	5003150	7600020
1002018	1003006ALT	2104519	3400650	3400915	3400992	5003150C	7600030
1002019	1003100	2104519	3400651	3400920	3400993	5003150C	7600031
1002020	1003105	2104520	3400652	3400920C	3400994	5003155C	7600040
1002021	1003200	2104520	3400653	3400921	3400995	5003155C	7600050
1002022	1003201	2104520	3400654	3400921C	3401002	5003165	7600060
1002023	1003202	2104520	3400655	3400922	3401003	5003165	7600070
1002024	1003203	2104525	3400656	3400922B	3401004	5003175	7600080
1002025	1003204	2104525	3400657	3400922C	3401004B	5003175	7600090
1002026	1003205	2104527	3400658	3400923	3401005	5003200	7600100
1002027	1003206	2104527	3400660	3400923C	3401006	5003200	7600209
1002028	1003207	2104528	3400661	3400924	3401007	5003250	7600210
1002029	1003208	2104528	3400860	3400924C	3600000	5003250	7600211
1002030	1003209	2104530	3400860B	3400925	3600000	5003300	7600211
1002033	1003525	2104530	3400861	3400926	5000400	5003300	7600502
1002035	1003526	2104531	3400862	3400926C	5000400	5003350	7600502
1002036	1105925	2104531	3400862B	3400930	5000401	5003350	7600503
1002038	1105975	3303040	3400863	3400930B	5000401	5900500	7600503
1002040	1160000	3321000	3400864	3400930C	5000402	5900550	7600504
1002041	1160000	3321000	3400865	3400931	5000402	5900551	7600504
1002042	1160002	3321001	3400870	3400931C	5003010	5900552	7600505
1002043	1160002	3321001	3400871	3400932	5003010	5900553	7600505
1002044	1160004	3321002	3400872	3400932B	5003020	5900554	7600506
1002045	1160004	3321002	3400873	3400932C	5003020	5900555	7600506
1002046	1160005	3321003	3400874	3400940	5003025	5900556	7600507
1002051	1160005	3321003	3400874B	3400940C	5003025	5900557	7600507
1002053	1160006	3321004	3400875	3400941	5003030	5900558	7600508
1002054	1160006	3321004	3400876	3400941C	5003030	5900559	7600508
1002055	1160007	3321005	3400877	3400942	5003040C	5900560	7600509
1002056	1160007	3321005	3400878	3400942B	5003040C	5900561	7600509
1002103	1170000	3321006	3400879	3400942C	5003045	5900562	7600510
1002104	1170000	3321006	3400882	3400965	5003045	5900563	7600510
1002105	1170001C	3321007	3400883	3400965B	5003050	5900564	7600513
1002106	1170001C	3321007	3400885	3400966	5003050	5900565	7600513
1002108	1170002	3321009	3400885B	3400967	5003050C	5900566	7600515
1002110	1170002	3321009	3400886	3400967B	5003050C	5900567	7600516
1002112	1170002	3321985	3400886B	3400968	5003060	5900568	7600518
1002115	1170002	3321985	3400887	3400969	5003060	5900569	7600518
1002116	1170003	3321986	3400888	3400970	5003070	5900570	

***Additional model numbers may appear on the next printing of these instructions.***



## LIMITED LIFETIME WARRANTY

**Warranty to End User:** D B Industries, Inc., dba CAPITAL SAFETY USA ("CAPITAL SAFETY") warrants to the original end user ("End User") that its products are free from defects in materials and workmanship under normal use and service. This warranty extends for the lifetime of the product from the date the product is purchased by the End User, in new and unused condition, from a CAPITAL SAFETY authorized distributor. CAPITAL SAFETY'S entire liability to End User and End User's exclusive remedy under this warranty is limited to the repair or replacement in kind of any defective product within its lifetime (as CAPITAL SAFETY in its sole discretion determines and deems appropriate). No oral or written information or advice given by CAPITAL SAFETY, its distributors, directors, officers, agents or employees shall create any different or additional warranties or in any way increase the scope of this warranty. CAPITAL SAFETY will not accept liability for defects that are the result of product abuse, misuse, alteration or modification, or for defects that are due to a failure to install, maintain, or use the product in accordance with the manufacturer's instructions.

CAPITAL SAFETY'S WARRANTY APPLIES ONLY TO THE END USER. THIS WARRANTY IS THE ONLY WARRANTY APPLICABLE TO OUR PRODUCTS AND IS IN LIEU OF ALL OTHER WARRANTIES AND LIABILITIES, EXPRESSED OR IMPLIED. CAPITAL SAFETY EXPRESSLY EXCLUDES AND DISCLAIMS ANY IMPLIED WARRANTIES OF MERCHANTABILITY OR FITNESS FOR A PARTICULAR PURPOSE, AND SHALL NOT BE LIABLE FOR INCIDENTAL, PUNITIVE OR CONSEQUENTIAL DAMAGES OF ANY NATURE, INCLUDING WITHOUT LIMITATION, LOST PROFITS, REVENUES, OR PRODUCTIVITY, OR FOR BODILY INJURY OR DEATH OR LOSS OR DAMAGE TO PROPERTY, UNDER ANY THEORY OF LIABILITY, INCLUDING WITHOUT LIMITATION, CONTRACT, WARRANTY, STRICT LIABILITY, TORT (INCLUDING NEGLIGENCE) OR OTHER LEGAL OR EQUITABLE THEORY.



The Ultimate in Fall Protection

### **CSG USA & Latin America**

3833 SALA Way  
Red Wing, MN 55066-5005  
Toll Free: 800.328.6146  
Phone: 651.388.8282  
Fax: 651.388.5065  
solutions@capitalsafety.com

### **CSG Canada**

260 Export Boulevard  
Mississauga, ON L5S 1Y9  
Phone: 905.795.9333  
Toll-Free: 800.387.7484  
Fax: 888.387.7484  
info.ca@capitalsafety.com

### **CSG Northern Europe**

5a Merse Road  
North Moons, Moat  
Reditch, Worcestershire, UK  
B98 9HL  
Phone: + 44 (0)1527 548 000  
Fax: + 44 (0)1527 591 000  
csgne@capitalsafety.com

### **CSG EMEA (Europe, Middle East, Africa)**

Le Broc Center  
Z.I. 1ère Avenue  
5600 M B.P. 15 06511  
Carros  
Le Broc Cedex  
France  
Phone: + 33 4 97 10 00 10  
Fax: + 33 4 93 08 79 70  
information@capitalsafety.com

### **CSG Australia & New Zealand**

95 Derby Street  
Silverwater  
Sydney NSW 2128  
AUSTRALIA  
Phone: +(61) 2 8753 7600  
Toll-Free : 1 800 245 002 (AUS)  
Toll-Free : 0800 212 505 (NZ)  
Fax: +(61) 2 87853 7603  
sales@capitalsafety.com.au

### **CSG Asia**

*Singapore:*  
16S, Enterprise Road  
Singapore 627666  
Phone: +65 - 65587758  
Fax: +65 - 65587058  
inquiry@capitalsafety.com

### *Shanghai:*

Rm 1406, China Venturetech Plaza  
819 Nan Jing Xi Rd,  
Shanghai 200041, P R China  
Phone: +86 21 62539050  
Fax: +86 21 62539060

[www.capitalsafety.com](http://www.capitalsafety.com)

